

The fully integrated longitudinal strapping for BAHMÜLLER POWERPACKER



- Damage-free bundling thanks to soft straps and product-dependent strap tension
- Variable strapping width 5-15mm, conversion approx. 15 minutes, optional
- ASC - Twin coil with Automatic Strap Change

EQUIPMENT:

- Torque controlled strap tension, adjustable
- Upstream and downstream interlocks
- Conveyor speed steplessly adjustable
- GreenTech energy concept, low power consumption
- Minimum strapping distance to the package side edge => optimal for 4-point boxes
- Bundle press
- SMART TOUCH 4.0 – Icon control concept
- Low maintenance and low wear technology
- Preparation for network access and remote maintenance access via VPN
- 2 strapping units

SMB CORIN-PP

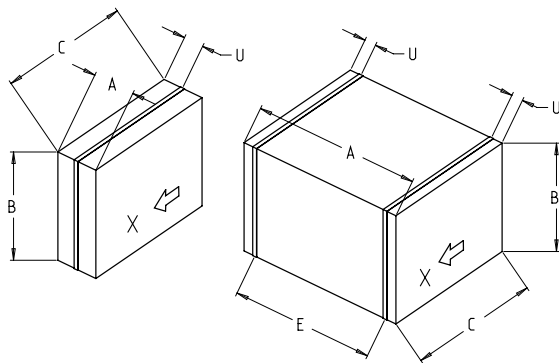
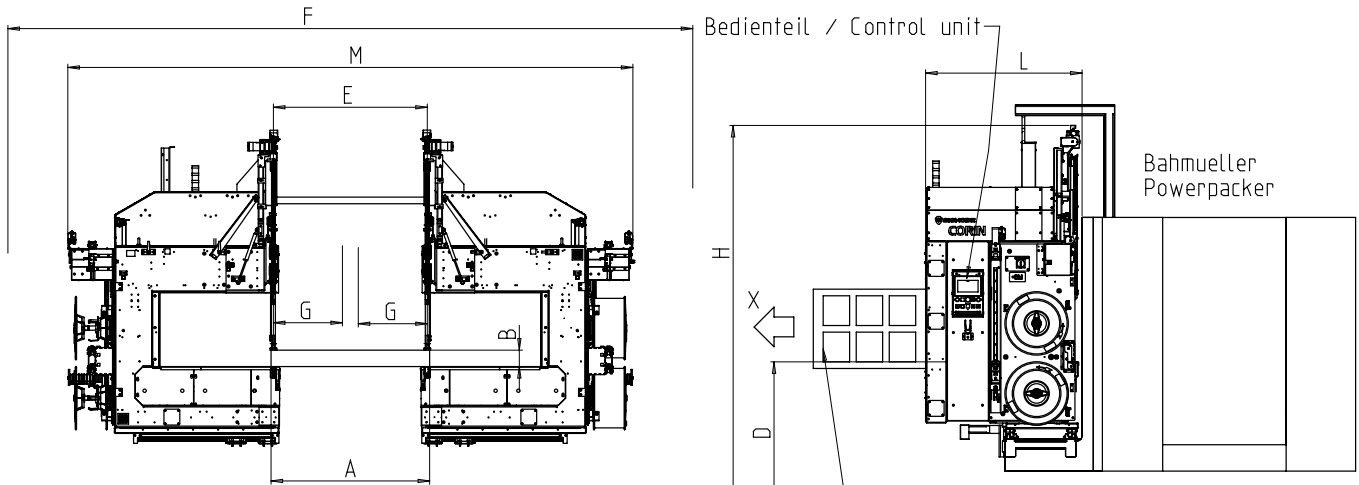

X = Paket-Durchlaufrichtung / bundle flow
alle Maße in mm / dimensions in mm

Verschützung nach CORIN
Lieferumfang; Bahmueller
Protection behind CORIN
Scope of delivery: Bahmueller

Machine width	M	3220-4340
Total length	L	1185
Total height	H	D + 1800
Table height	D	Powerpacker
bundle width (1x strapped)	A	150-1300
bundle width (2x strapped)	A	215-1300
max. bundle height	B	400
Bundle length	C	150-1050
Distance between straps (2x strapped)	E	155-1240
Moving path	G	-160 ... 560
Additional space needed	F	5350
Strap distance to outer edge	U	30

TECHNICAL SPECIFICATION:

CAPACITY:

Bundles/minute: 30
Based on bundle size l x w x h in mm: 210 x 300 x 100

BUNDLES:

(see drawing)
Weight in kg: max. 30

TRANSPORT SPEED:

m/s: 0,40 - 2,00

STRAP TENSION:

Steplessly adjustable

STRAPPING MATERIAL:

Polypropylene DIN EN 13 394
Width in mm: 5 - 15
Thickness in mm: 0,25 - 0,55

SEALING METHOD:

Heat seal. Tensile strength of welded joint is approx. 80% of the breaking strength of the strap

STRAP COIL:

Core ID in mm: 200
Core OD in mm: 420
Width in mm: 190 (160,180,200)
Other coil sizes on request

POWER SUPPLY:

Wide Range Input 380-520V, 3AC; 47 63 Hz
Maximum fusing 16A (B-character)

POWER CONSUMPTION:

Power consumption in kW approx.: 0,8

WEIGHT:

Total weight approx. in kg: 1800

OPERATING CONDITIONS:

Temperature range in °C [°F]: +5 [41] - +45 [113]



A SIGNODE BRAND

Signode Packaging Systems GmbH

Markgrafenstraße 2 | D-95497 Goldkronach | Germany
Tel.: +49 (0) 9273 / 982-201 | Fax.: +49 (0) 9273 / 982-100
www.smb.biz | sales@smb.biz

