

The most variable fully automatic strapping machine



- User-friendly and intuitive
- Economical owing to highest availability
- Robust and extremely low maintenance
- Powerful
- Maximum flexibility & adaptability

EQUIPMENT:

- 5000 bundle recipes
- ASLF 'Anti-Strap-Loss-Function' Constant strap control
- Strap width 5 - 9 mm, adjustable
- Automatic strap threading, soft
- Strap end detection system with automatic discharge of remaining strap
- Automatic strap tensioning, stepless
- Strap coil detection with yellow indicator lamp
- DAT 'Direct-Access-Technology'
- The exclusive eject function avoids strap jam
- Torque controlled strap tension, adjustable
- Upstream and downstream interlocks with complete plug connection
- EPP 'Exact Product Path'
- Conveyor speed steplessly adjustable
- GreenTech energy concept, low power consumption
- Signal light tower: operation and failure
- MFT 'Mono-Frame-Technology'
- Bundle stops, no contact with bundle when clearing the bundle, adjustable from operating side
- Bundle press at both sides of the strapping line
- Plexiglass side doors, screwed
- Production data analysis via Ethernet/USB
- SMART TOUCH – Icon control concept
- Wear-free, energy saving direct-drive-motors
- Wear-free Strap-frame by stainless steel guide
- XL-Coil
- Many specific options available, easily configurable

SMB NP7000 4.0

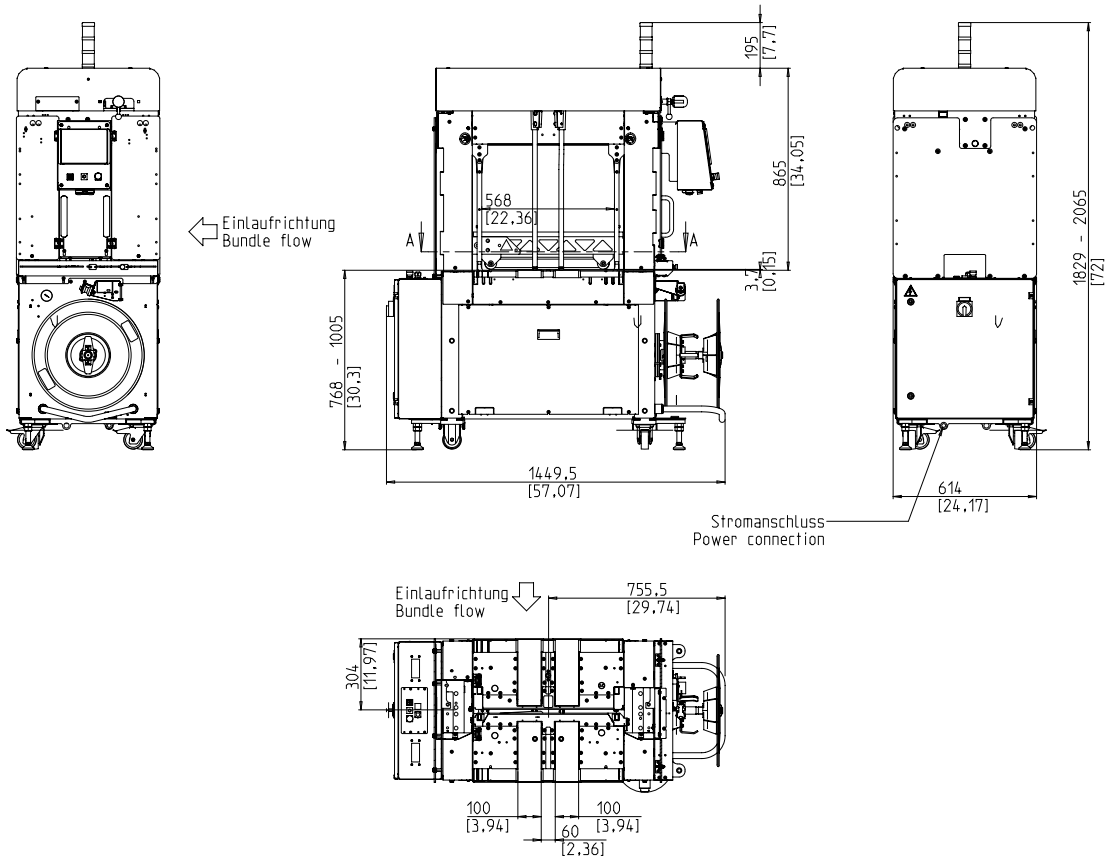

TECHNICAL SPECIFICATION:

CAPACITY:

Single strap, bundles/minute up to:	50
At table belt speed in m/s:	1
Based on bundle size l x w in mm:	300 x 210
Without bundle press	

BUNDLES:

Width in mm	
Min.:	100
Max.:	600
Length in mm:	min. 150
Height in mm	
Min.:	5
Max.:	380
(see drawing)	
Weight in kg:	max. 25

TRANSPORT SPEED:

m/s:	0,20 - 1,00
------	-------------

STRAP TENSION:

Steplessly adjustable	
Automatic strap tensioning, stepless, depending on height of bundle	
Tension at bundle in N:	max. 450
Tension path in mm:	max. 200

STRAPPING MATERIAL:

Polypropylene DIN EN 13 394	
Width in mm:	5 - 9
Thickness in mm:	0,4 - 0,65

SEALING METHOD:

Heat seal. Tensile strength of welded joint is approx. 80% of the breaking strength of the strap

STRAP COIL:

Core ID in mm:	228 / 200
Core OD in mm:	420
Width in mm:	190 (160,180,200,228)

POWER SUPPLY:

Wide Range Input 380-520V, 3AC; 47 63 Hz	
Maximum fusing 16A (B-character)	
Protection Type:	IP 54

POWER CONSUMPTION:

Power consumption in kW approx.:	0,30
----------------------------------	------

PNEUMATICS:

Operating pressure in bar:	6
Air consumption per cycle in l (free air):	7

WEIGHT:

Total weight approx. in kg:	380
-----------------------------	-----

OPERATING CONDITIONS:

Temperature range in °C [°F]:	+5 [41] - +45 [113]
-------------------------------	---------------------



Signode Packaging Systems GmbH

Markgrafenstraße 2 | D-95497 Goldkronach | Germany
 Tel.: +49 (0) 9273 / 982-201 | Fax.: +49 (0) 9273 / 982-100
 www.smb.biz | sales@smb.biz

